

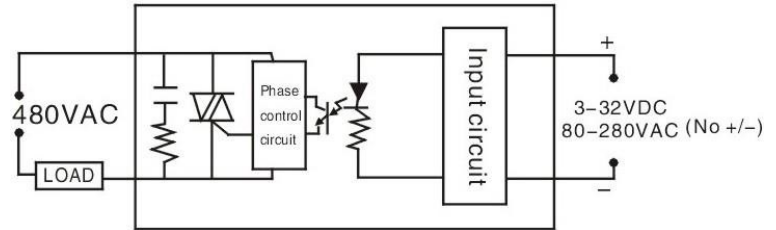

Features

- Load current 10-120A
- Built-in RC
- LED indicator
- Zero-cross
- DC or AC control

Dimension

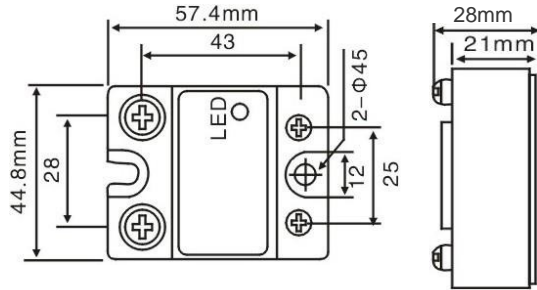

Specification

MODEL	ATO-SYDH□48ZD3	ATO-SYDH□48ZA2
INPUT		
Control voltage range	3-32V DC (D3)	70-280V AC (A2)
Max. input current	12mA	15mA
Must operate voltage	2.8V DC	70V AC
Must release voltage	1.5V DC	50V AC
OUTPUT		
Load voltage range	24-480V AC	
Peak voltage	800V AC	
Load current	10A, 15A, 20A, 25A, 40A, 50A, 60A, 75A, 80A, 100A, 120A	
Max. off-state leakage current	2mA	
Max. on-state voltage drop	1.5V	
GENERAL		
Dimension (L – W – H)	57.4x44.8x28mm	
Weight (approx.)	100g	
Dielectric strength (input to output)	4000V	
Dielectric strength (input, output to the base)	2500V	
Operating temperature	-20°C~80°C	
Certification	CE	

Notes:

1. When choosing a solid state relay, please pay attention to the actual load current and working ambient temperature. Heat sink or other cooling methods needs to be taken during the operation.
2. When SSR is working, the heat generated needs to be dissipated through the metal base plate. Please make sure the firm installation of the relay and heat sink, and apply thermal grease between the SSR and heat sink.
3. Tighten the SSR terminal screws properly.
4. Please do not use the solid state relay beyond the descriptions in the data sheet.

Features

- DC or AC control
- Load current 10-120A
- Built-in RC
- LED indicator
- Zero-cross



Dimension

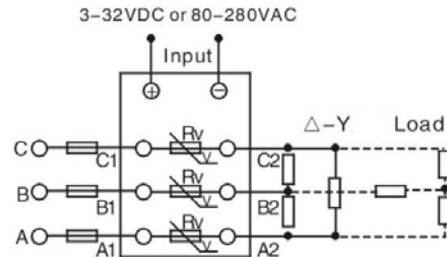
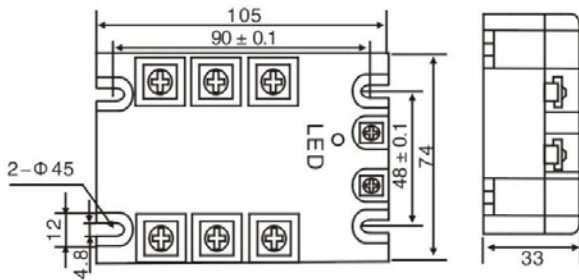

Specification

MODEL	ATO-SYTH□48ZD3	ATO-SYTH□4 8ZA2
INPUT		
Control voltage range	3-32V DC (D3)	70-280V AC (A2)
Max. input current	40mA	15mA
Must operate voltage	4V DC	70V AC
Must release voltage	2.7V DC	50V AC
OUTPUT		
Load voltage range	24-480V AC	
Peak voltage	1000V AC	
Load current	10A, 15A, 20A, 25A, 40A, 50A, 60A, 75A, 80A, 100A, 120A	
Max. off-state leakage current	≤8mA	
Max. on-state voltage drop	1.5V	
GENERAL		
Dimension (L – W – H)	105x74x33mm	
Weight (approx.)	500g	
Dielectric strength (input to output)	4000V AC	
Dielectric strength (input, output to the base)	2500V AC	
Operating temperature	-20°C~80°C	
Certification	CE	

- Notes:**
1. When choosing a solid state relay, please pay attention to the actual load current and working ambient temperature. Heat sink or other cooling methods needs to be taken during the operation.
 2. If the load can bring high surge current (such as bulb, etc.), make sure that SSR can bear the surge current.
 3. The SSR surge current in the above specification is non-repetitive surge current peak. Generally, half of the non-repetitive current peak is regarded as a standard value. Thus, if a surge current through the SSR exceed this standard value, a fast fuse should be connected to output terminal, so as to avoid the damage of SSR.
 4. If an instantaneous voltage added to the output terminal of SSR exceeds the range in the spec, a varistor should be connected to output terminal in parallel. 750V varistor is recommended.

ATO industrial solid state relays (SSRs) have optional load current: 60 Amp, 80 Amp, 100 Amp, 120 Amp, 150 Amp, 200 Amp, 250 Amp, 300 Amp and 350 Amp, allowing you to drive high-current 24-440V AC load through 3-32V DC low control voltage. The SSR relays are greatly suitable for petrochemical equipment, pharmaceutical machines, food machines, packaging machines, plastic machines, CNC machine tool and entertainment facilities, and other automatic control systems.

Dimensions

■ ATO-GYSSR-60DA (H₁)

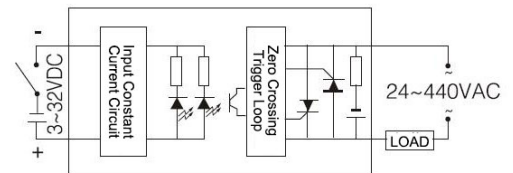
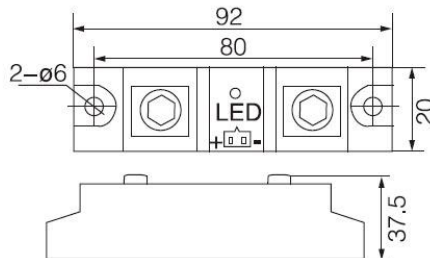

■ ATO-GYSSR-120DA (H₂)

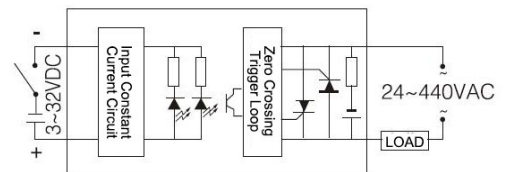
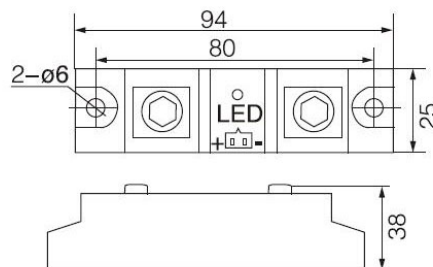

■ ATO-GYSSR-200DA (H₃)

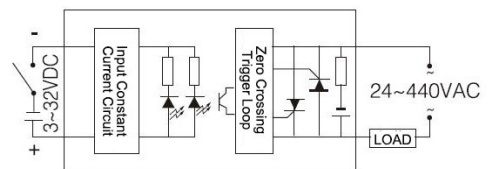
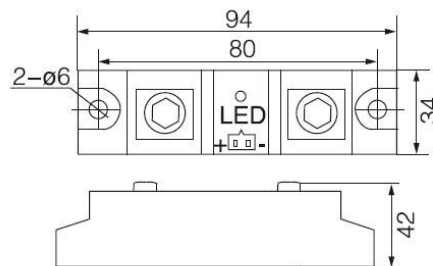

■ ATO-GYSSR-350DA (H₄)

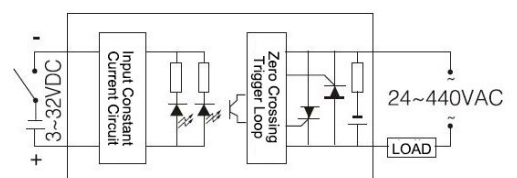
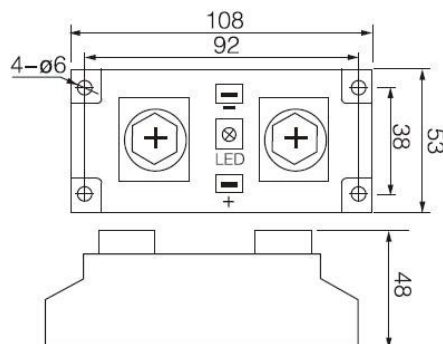

Specification



■ ATO-GYSSR-60DA (H₁)

Model	ATO-GYSSR60DA(H1)
Control Voltage	3-32V DC
Control Current	DC 7-32mA
Load Current	60A
Load Voltage	24-440V AC
On-State Voltage Drop	≤1.5V
Off-State Leakage Current	≤4mA
Off-State Time	≤10mS
Dielectric Strength	2500V AC
Insulation Resistance	1000MΩ/ 500V DC
Ambient Temperature	-20 ~ +70°C
Mounting Method	Bolt Fixing
Working Indicator	LED
Weight	120g
Dimension (L*W*H)	92*20*37.5mm

■ ATO-GYSSR-120DA (H₂)



Model	ATO-GYSSR80DA(H2)	ATO-GYSSR100DA(H2)	ATO-GYSSR120DA(H2)
Control Voltage	3-32VDC		
Control Current	DC 7-32mA		
Load Current	80A	100A	120A
Load Voltage	24-440V AC		
On-State Voltage Drop	≤1.5V		
Off-State Leakage Current	≤4mA		
Off-State Time	≤10mS		
Dielectric Strength	2500V AC		
Insulation Resistance	1000MΩ/ 500V DC		
Ambient Temperature	-20 ~ +70°C		
Mounting Method	Bolt Fixing		
Working Indicator	LED		
Weight	145g		
Dimension (L*W*H)	94*25*38mm		

■ ATO-GYSSR-200DA (H₃)



Model	ATO-GYSSR150DA(H3)	ATO-GYSSR200DA(H3)	ATO-GYSSR250DA(H3)	ATO-GYSSR300DA(H3)
Control Voltage	3-32VDC			
Control Current	DC 7-32mA			
Load Current	150A	200A	250A	300A
Load Voltage	24-440V AC			
On-State Voltage Drop	≤1.5V			
Off-State Leakage Current	≤4mA			
Off-State Time	≤10mS			
Dielectric Strength	2500V AC			
Insulation Resistance	1000MΩ/ 500V DC			
Ambient Temperature	-20 ~ +70°C			
Mounting Method	Bolt Fixing			
Working Indicator	LED			
Weight	230g			
Dimension (L*W*H)	94*34*42mm			

■ ATO-GYSSR-350DA (H₄)



Model	ATO-GYSSR350DA(H4)
Control Voltage	3-32V DC
Control Current	DC 7-32mA
Load Current	350A
Load Voltage	24-440V AC
On-State Voltage Drop	≤2V
Off-State Leakage Current	≤4mA
Off-State Time	≤10mS
Dielectric Strength	2500V AC
Insulation Resistance	1000MΩ/ 500V DC
Ambient Temperature	-20 ~ +70°C
Mounting Method	Bolt Fixing
Working Indicator	LED
Weight	560g
Dimension (L*W*H)	108*53*48mm

Operation Note:

1. For the resistive load, it cannot exceed 60% of the rated current of the solid state relay.
2. For the inductive or capacitive load, it cannot exceed 40% of the rated current of the solid state relay.
3. For the electric motor, it cannot exceed 20% of the rated current of the solid state relay.
4. Proper radiator or heat sink should be equipped for the industrial solid state relay. If the load cooling condition is not good, it is necessary to leave some margin. Avoid the load short circuit because over current and short circuit are the main causes for permanent damage of the internal SCR of the SSR.
5. Over current protection: Using fast fuse and air switch is one of the methods for over current protection; fuse is also available for small capacity.
6. Over voltage protection: It can adopt the parallel voltage-dependent resistor (MOV). The MOV area decides the absorption power, and its thickness decides the protective voltage value. Generally, 471/10D voltage-dependent resistor is suitable for 220V series SSR, 681/10D voltage-dependent resistor for 380V series SSR, and 821/10D voltage-dependent resistor for 480V series SSR.

The aluminum heat sink radiator is suitable for one or three pieces of industrial-grade single phase solid state relay or one piece of three phase solid state relay.

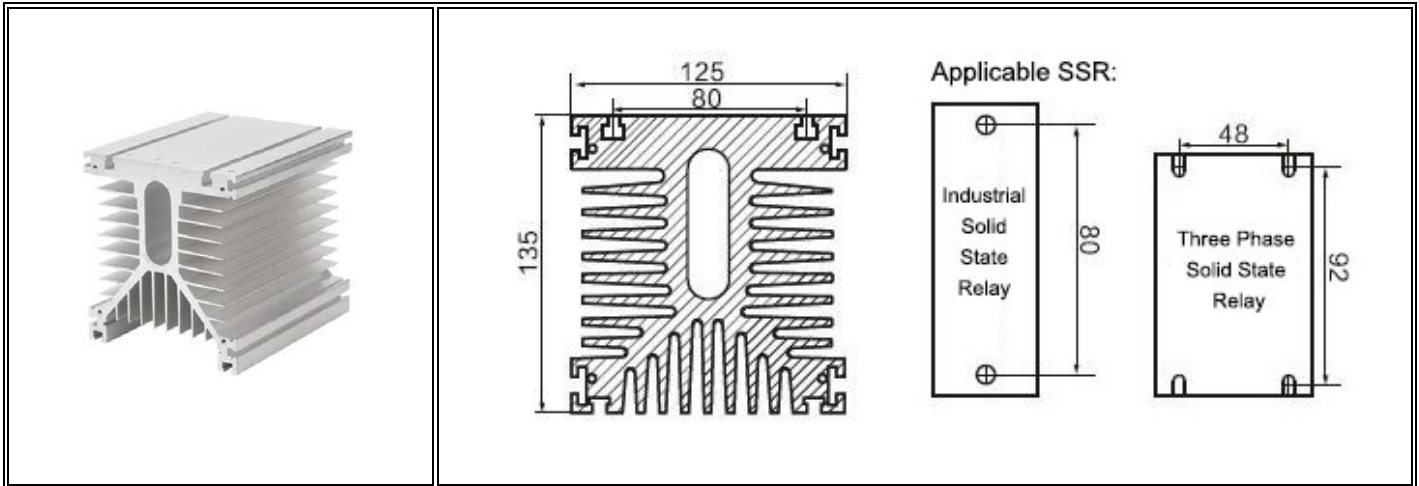

Model	Dimension (mm) (L×W×H)	Application Range
ATO-L-150	150 × 125 × 135	<ol style="list-style-type: none"> 1. Applied for three industrial single phase solid state relays with actual load current (three phase amount) less than 220A 2. Applied for a three-phase solid state relay with actual load current (three phase amount) less than 210A 3. Applied for one industrial single phase solid state relay with actual load current less than 220A
ATO-L-200	200 × 125 × 135	<ol style="list-style-type: none"> 1. Applied for three industrial single phase solid state relays with actual load current (three phase amount) less than 300A 2. Applied for one industrial single phase solid state relay with actual load current less than 300A
ATO-L-250	250 × 125 × 135	<ol style="list-style-type: none"> 1. Applied for three industrial single phase solid state relays with actual load current (three phase amount) less than 350A 2. Applied for one industrial single phase solid state relay with actual load current less than 350A
ATO-L-300	300 × 125 × 135	<ol style="list-style-type: none"> 1. Applied for three industrial single phase solid state relays with actual load current (three phase amount) less than 400A 2. Applied for one industrial single phase solid state relay with actual load current less than 400A
ATO-L-400	400 × 125 × 135	<ol style="list-style-type: none"> 1. Applied for three industrial single phase solid state relays with actual load current (three phase amount) less than 500A 2. Applied for one industrial single phase solid state relay with actual load current less than 500A

Note: The above actual load current is calculated based on that the heat sink is installed with a cooling fan (38*120*120mm) at the one end, and the length should be increased by 38mm after the fan is installed.