

Three-phase Voltage Monitoring Relay JVR800-2

Features

- Compact modular 43mm housing
- Microprocessor technology provides highly accurate and repeatable protection
- Built-in LCD and keypad afford a precise digital setting
- Adjustable over- and undervoltage, phase unbalance threshold
- Independent adjustable delay time for overvoltage, undervoltage, voltage unbalance, phase loss and phase sequence
- Adjustable reset method: automatic reset or manual reset
- 1 NO & 1 CO contacts
- Fault recording with last 3 faults
- with Timer and Counter



Protective Functions

- Phase Loss (Failure)
- Phase Sequence (Reversal)
- Voltage Unbalance (Asymmetry)
- Undervoltage
- Overvoltage

Applications

- Pumps
- Fans
- Refrigeration Units
- Blowers
- Motors
- Compressors
- Lifts, Elevators
- Cranes
- Mining excavators and conveyors

Ordering Information

Model	Rated Voltage	Operating Range
JVR300-2	208-480VAC, 50/60Hz	150-600VAC

Technical data

Rated supply voltage	208-480VAC
Operating Range	150-600VAC
Operating frequency	50/60Hz
Max counting capacity	999999
Max timing capacity	9999H59M
Max counting frequency	5Hz
Total timing error	≤0.001%
Counting input signal	AC/DC 80-450V
Measurement error	≤1% with adjustable voltage range
Data retention time	10 years
Output type	1NO & 1CO
Contact capacity	6A, 250VAC/30VDC (resistive load)
Degree of protection	IP 20
Working conditions	-25°C~65°C, ≤85%RH, non-condensing
Mechanical durability	1000000 cycles
Dielectric strength	>2kVAC 1min
Weight	130g
Dimensions (H x W x D)	80X43X54mm
Mounting	35mm DIN rail

Front Panel View

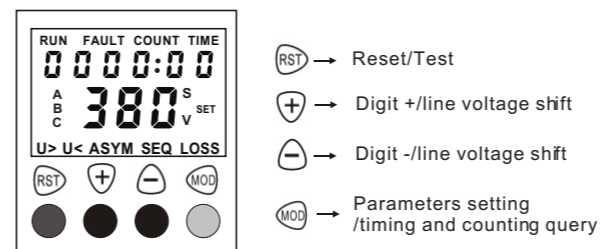

LCD Indication	Description
0000:00	timing and counting value
380 V	line voltage
A B C	phase indication, shift by + -
SET	parameters setting indication
RUN COUNT	The counting times of running, shift by MOD
RUN TIME	The time of running, shift by MOD
FAULT COUNT	The number of faults, shift by MOD
FAULT TIME	The time of faults, shift by MOD
U>	Overvoltage fault indication or overvoltage setting indication
U<	Undervoltage fault indication or Undervoltage setting indication
ASYM	Voltage unbalance (Asymmetry) fault indication or phase unbalance setting indication
SEQ	Phase sequence fault indication or phase sequence setting indication
LOSS	Phase loss fault indication or phase loss setting indication

Parameter Setting Method

Press and hold key MOD for 3 seconds to get into parameter setting interface, then press MOD to shift to next parameter, press + - to set up the values. Long press + - could accelerate increase or decrease. Press RST to exit setting.

LCD indication	Parameters	Setting range	Default
437 V	overvoltage threshold	200-600V, OFF *1	437V
5.0 S	overvoltage delay time	0.1-999s	5s
323 V	undervoltage threshold	OFF, 150-500V	323V
5.0 S	undervoltage delay time	0.1-999s	5s
HYS 5 V	voltage hysteresis	1-20V	5V
15 %	voltage unbalance ratio	1%-50%, OFF *2	15%
5.0 S	voltage unbalance delay time	0.1-999s	5s
HYS 2 %	voltage unbalance hysteresis	1%-10%	2%
0.5 S	phase loss delay time	0.1-30.0s, OFF	0.5s

Following next page...

Parameter Setting Method

(Continued)

LCD indication	Parameters	Setting range	Default
0.5 S	phase sequence delay time	0.1-30.0s, OFF	0.5s
StArt 0 S	start delay time	0-999s *3	0s
rSt ON	auto reset mode	ON/OFF	ON
rSt 5.0 S	auto reset time	0.1-999s	5s
dFlt No	restore factory default	YES/NO	NO
clr No	clear records	NO/YES/OFF *4	NO
Frq 50	voltage frequency	50/60Hz	50Hz
r3.0	item version	ver 3.0	---
End	exit	---	---

Note:

1. "ON" means enable the function, "OFF" means disable the function.
2. Voltage unbalance factor (%) = $(\frac{|U_{line\ voltage} - U_{line\ average}|}{\max(U_{line\ average})}) \times 100\%$.
3. Start delay time is equivalent to power-on delay time.
4. Timer and counter records for running and faults will be clear all if this function is YES.
5. The relay would automatically exit setting interface if any key is not pressed for consecutive 30 seconds.

Start Delay /Power-on Delay

If start delay time is set, start delay will be active when power is turned on, the display shows "Start" and countdown. The display will get into the voltage display when countdown expires.



Test Trip

Pressing RST more than 3sec to activate the test trip mode, all the output contacts will trip when 3s expires. The display shows "test" and countdown, when the test is done, the display shows "End". By pressing RST, returns to the voltage display mode. Before 3s expires, pressing RST blocks the test trip and return to the voltage display.

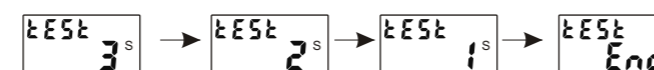

Dimensions (mm)

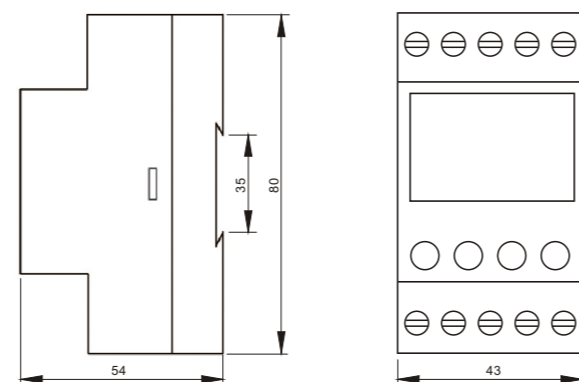

Fault History Check

Pressing MOD more than 3sec, it displays the latest fault cause and the fault voltage. Press MOD to check later fault continually. Press + or - to shift the display of other two line voltage. Press MOD after Log3 to exit or press RST directly to exit. The oldest fault record is over written when the number of fault to record exceeds three.

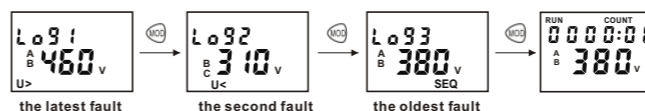

Wiring Diagram

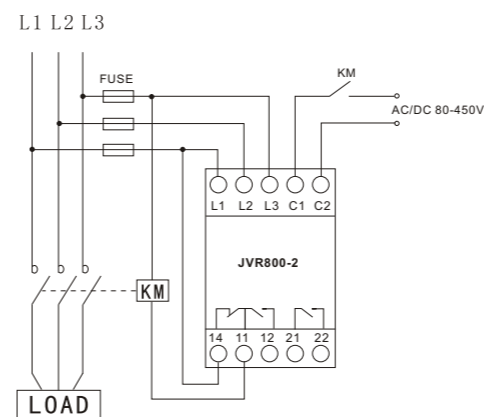

Relay contact position shown in 'Power on' (Healthy) condition

Note: specifications are subject to change without notice.

GENERAL SAFETY
POTENTIALLY HAZARDOUS VOLTAGES ARE PRESENT AT THE TERMINALS OF THE RELAYS. ALL ELECTRICAL POWER SHOULD BE REMOVED WHEN CONNECTING OR DISCONNECTING WIRING. THIS DEVICE SHOULD BE INSTALLED AND SERVICED BY QUALIFIED PERSONNEL.

If you have any questions, please contact us...

ATO

Email: sales@atorelays.com
Tel: +86 773-363-7977
Address: Land Building, Hongling Rd, Xiufeng District, Guilin City, Guangxi Province, China, 541000